

FOR 8IN. SIZE HOLES ARE LOCATED AT 60°, 120°, 240° AND 300°. WHEN USING ONLY TWO BOLTS THE 120° AND 300° LOCATIONS SHALL BE USED.

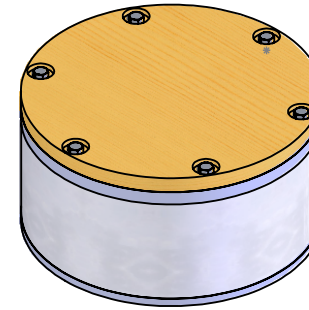

NOTE:

1. 'HT'= HEIGHT TO ORDER. MINIMUM HEIGHT IS 2.0" WHEN USED IN OVERLAY PAVING.
2. (6) CEC LOCK WASHERS ARE SHIPPED UNASSEMBLED WITH THE L-868 EXTENSION.
3. PLYWOOD COVER FOR L-868 TOP SECTION IS GRADE CC.
 - L-868 8" NOM. OD: 3/4" THICK
 - L-868 12" NOM OD: 3/4" THICK
 - L-868 15" NOM OD: 1 1/4" THICK
4. CARBON STEEL EXTENSIONS ARE HOT DIP GALVANIZED PER ASTM A123.
5. AVAILABLE OPTIONS, SPECIFIED WHEN ORDERING, INCLUDE:
 - ANTI-ROTATION FINS
 - LOAD RING
 - STAINLESS STEEL CONSTRUCTION
 - REPLACEABLE STAINLESS STEEL THREADED INSERTS
6. THIS PRODUCT IS CERTIFIED PER FAA ADVISORY CIRCULAR AC150/5345-42 (CURRENT REV).

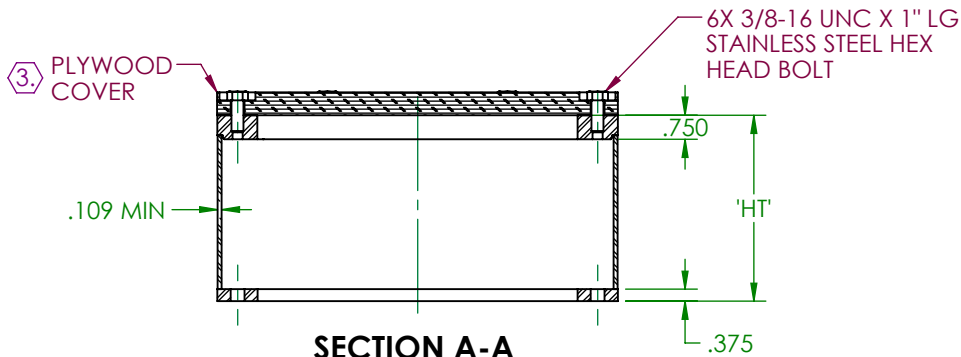

SECTION A-A
WITH PLYWOOD COVER
AND MACHINE SCREWS

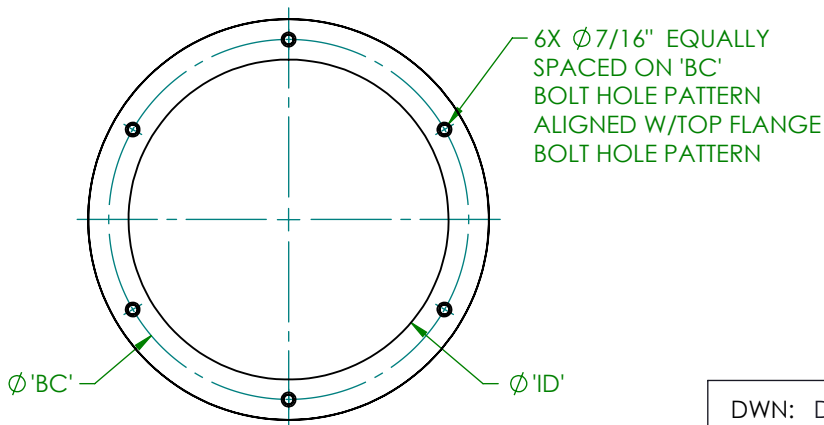

BOTTOM VIEW

FAA TYPE	NOM DIA	MMC TYPE	'OD'	'BC'	'ID'
L-868A	8"	88E	8.500	7.250	6.500
L-868B	12"	128E	12.500	11.250	10.000
L-868C	15"	158E	15.500	14.250	13.000

DWN: DOUG F.	L-868 EXTENSION		
DATE: 8/11/2017			
SCALE: NTS		622 6TH ST. SO. WINSTED, MN 55395	8E
SHEET 1 OF 1			