



# SJ1 (TAPERED ARM) CARBON STEEL

## ANCHOR BOLTS

Anchor bolts conform to ASTM F1554 Grade-55 standards. Bolts have an "L" bend at one end and a minimum of 12" galvanized threads on the other end. Two galvanized flat washers per ASTM F436 and two galvanized hexagonal nuts per ASTM A563 Grade DH are provided with each bolt.

## ANCHOR BASE

The base plate is fabricated from ASTM A36 carbon steel. The base is fabricated with slotted bolt holes to allow for a +/- 0.5" variance in listed nominal bolt circle size. The base plate telescopes the pole shaft and is circumferentially welded top and bottom.

## HIGH BASE

Each pole assembly is fashioned with a Millerbernd Manufacturing Company High Base. The base is fabricated from the same material as the pole shaft and stands 27 inches tall. The pole shaft is slip fitted and welded to the base.

## DIRECT-EMBEDDED BASE

Each pole assembly is fashioned with a direct embedded base. The base extends below the ground line and is fitted with a 1 inch coupling located 2' below the ground line for wire entrance. The direct embedded base is fashioned with an anti-rotation bearing strap on the bottom of the base.

## SHAFT

The pole shaft conforms to ASTM A1011 Grade 50 carbon steel standards.

## HANDHOLE

A reinforced handhole with cover, grounding lug, and hardware is provided with each pole assembly. Pole assemblies fabricated with a High-Base are provided with a flush mounted handhole with cover, grounding lug, and hardware.

## ARMS

SJ1 arms are formed from 11 gauge ASTM A1011 Grade 50 carbon steel. Each SJ1 arm attaches to the pole shaft with a three bolt simplex plate. Each SJ1 arm has a rise of 3 feet and 3 inches from the pole top and is fitted with a 2.38" diameter pipe adapter.

## FINISHING

Carbon steel poles may be specified as hot-dip galvanized per ASTM A123 and/or finish painted with our standard Millerbond Wet Coat Finish.

## HARDWARE

All hardware and fasteners are supplied with each pole assembly. All structural fasteners are galvanized high-strength carbon steel.



ARM ATTACHMENT DETAIL

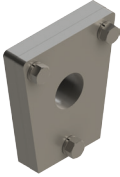

TWIN ARM ARRANGEMENT



CROSS SECTION OPTIONS

Round

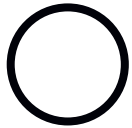

Octagonal

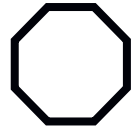

16-Sided

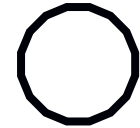

Mounting Height

BASE OPTIONS

Anchor Base (A)

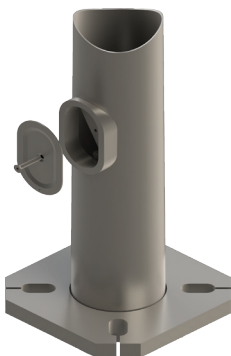

High-Base (H)

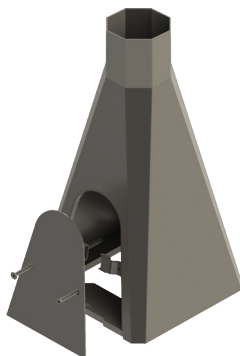

Direct-Embed (D)

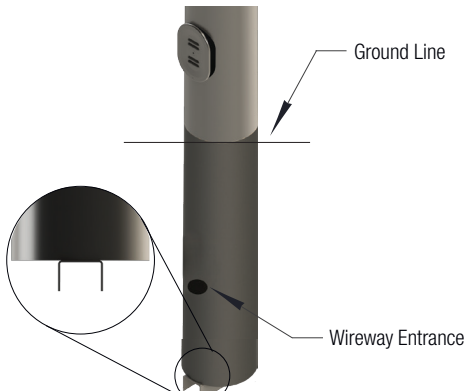



### ANCHOR BASE

PART#	MOUNTING HEIGHT (FT)	MAX ARM LENGTH (FT)	WEIGHT (LBS.)	BASE O.D. (IN)	TOP O.D. (IN)	BOLT CIRCLE +/- 0.5 (IN)	BASE SQUARE (IN)	MAX EPA 90 MPH	MAX EPA 100 MPH	MAX EPA 110 MPH	MAX EPA 120 MPH	MAX EPA 130 MPH	MAX EPA 140 MPH	MAX EPA 150 MPH
SJ1-171-A-060-A-200	20	17	206	6	3.62	9	9	1.95	1.95	1.95	1.95	1.95	1.95	1.95
SJ1-171-A-070-A-250	25	17	254	7	3.92	10	10	2.27	2.27	2.27	2.27	2.27	2.27	2.01
SJ1-171-A-080-A-300	30	17	313	8	4.22	11	11	2.68	2.68	2.66	2.68	2.68	2.38	1.39
SJ1-171-A-080-A-350	35	17	343	8	3.52	11	11	1.04	1.04	1.04	1.04	1.04	0.61	
SJ1-171-A-085-A-350	35	17	369	8.5	4.02	11.5	11.5	2	2	2	2	2	1.94	0.8
SJ1-171-A-090-A-400	40	17	423	9	3.82	12.5	12.5	1.48	1.48	1.48	1.48	1.48	0.82	
SJ1-171-A-105-A-500	50	17	558	10.5	3.45	14	14	1.49	1.49	1.49	0.51			

### DIRECT-EMBEDDED BASE

PART#	MOUNTING HEIGHT (FT)	MAX ARM LENGTH (FT)	WEIGHT (LBS.)	BASE O.D. (IN)	TOP O.D. (IN)	BURIAL DEPTH (FT)	MAX EPA 90 MPH	MAX EPA 100 MPH	MAX EPA 110 MPH	MAX EPA 120 MPH	MAX EPA 130 MPH	MAX EPA 140 MPH	MAX EPA 150 MPH
SJ1-171-D-060-A-200	20	17	158	6	3.62	5	1.95	1.95	1.95	1.95	1.95	1.95	1.95
SJ1-171-D-070-A-250	25	17	206	7	2.92	5	2.27	2.27	2.27	2.27	2.27	2.27	2.01
SJ1-171-D-080-A-300	30	17	263	8	2.72	6	2.68	2.68	2.68	2.68	2.68	2.38	1.39
SJ1-171-D-080-A-350	35	17	287	8	2.52	6	1.04	1.04	1.04	1.04	1.04	0.61	
SJ1-171-D-085-A-350	35	17	307	8.5	4.02	6	2	2	2	2	2	1.94	0.8
SJ1-171-D-090-A-400	40	17	354	9	3.82	7	1.48	1.48	1.48	1.48	1.48	0.82	
SJ1-171-D-105-A-500	50	17	489	10.5	3.45	8	1.49	1.49	1.49	0.51			

### HIGH-BASE

PART#	MOUNTING HEIGHT (FT)	MAX ARM LENGTH (FT)	WEIGHT (LBS.)	BASE O.D. (IN)	TOP O.D. (IN)	BOLT CIRCLE (IN)	BASE SQUARE (IN)	MAX EPA 90 MPH	MAX EPA 100 MPH	MAX EPA 110 MPH	MAX EPA 120 MPH	MAX EPA 130 MPH	MAX EPA 140 MPH	MAX EPA 150 MPH
SJ1-171-H-070-A-200	20	17	226	7	4	15	15	3.57	3.57	3.57	3.57	3.57	3.57	2.58
SJ1-171-H-070-A-250	25	17	252	7	4	15	15	2.25	2.25	2.25	2.25	2.25	1.47	
SJ1-171-H-086-A-300	30	17	330	8.6	4	15	15	2.45	2.45	2.45	2.45	2.45	2.13	0.73
SJ1-171-H-096-A-350	35	17	357	9.6	4	15	15	2.29	2.29	2.29	2.29	2.29	1.2	
SJ1-171-H-096-A-400	40	17	429	9.6	4	15	15	1.73	1.73	1.73	1.73			
SJ1-171-H-106-A-500	50	17	562	10.6	4	15	15	1.64	1.64	1.64				

- Variations from above sizes are available. Consult factory for allowable weight and EPA ratings for custom sizes.
- Charts are for single arm configurations only. Consult factory for allowable weight and EPA ratings on twin arm arrangements.
- Charted weights include the base, pole shaft, and luminaire mounting arm.
- The "Base O.D." measurement for direct-embedded structures is taken at the ground line.

Design	Arm Span	Base Style	Base Diameter	Wall Thickness	Mounting Height	Cross-Section	Finish	Options
SJ1 -	081 = 8' 101 = 10' 121 = 12' 151 = 15' 171 = 17'	A = Anchor H = High D = Direct Embed	Base diameter is identified with one decimal place to identify diameter in inches. (e.g. 094 = 9.4")	A = 11 GA B = 7 GA C = 3/16" D = 1/4 "	Mounting height is identified with one decimal place to identify height in feet. (e.g. 255=25.5')	R = Round H = 8-Sided W = 16-Sided	GV = Hot Dip-Galvanize FP = Finish Paint GP = Paint Over Galvanize	Insert Part Number for options, separated by "-"