



SPI (PIPE ARM) CARBON STEEL

ANCHOR BOLTS

Anchor bolts conform to ASTM F1554 Grade-55 standards. Bolts have an "L" bend at one end and a minimum of 12" galvanized threads on the other end. Two galvanized flat washers per ASTM F436 and two galvanized hexagonal nuts per ASTM A563 Grade DH are provided with each bolt.

ANCHOR BASE

The base plate is fabricated from ASTM A36 carbon steel. The base is fabricated with slotted bolt holes to allow for a +/- 0.5" variance in listed nominal bolt circle size. The base plate telescopes the pole shaft and is circumferentially welded top and bottom.

HIGH BASE

Each pole assembly is fashioned with a Millerbernd Manufacturing Company High Base. The base is fabricated from the same material as the pole shaft and stands 27 inches tall. The pole shaft is slip fitted and welded to the base.

DIRECT-EMBEDDED BASE

Each pole assembly is fashioned with a direct embedded base. The base extends below the ground line and is fitted with a 1 inch coupling located 2' below the ground line for wire entrance. The direct embedded base is fashioned with an anti-rotation bearing strap on the bottom of the base.

SHAFT

The pole shaft conforms to ASTM A1011 Grade 50 carbon steel standards.

HANDHOLE

A reinforced handhole with cover, grounding lug, and hardware is provided with each pole assembly. Pole assemblies fabricated with a High-Base are provided with a flush mounted handhole with cover, grounding lug, and hardware.

ARMS

SP1 arms are fabricated from 2" (2.38" O.D.) schedule 40 pipe. Each SP1 arm attaches to the pole shaft with a cast steel, mating 4-bolt simplex bracket (optional cast steel, mating 1-bolt (1BS) or 2-bolt (2BS) simplex brackets are available. SP1 arms have a rise of 3 feet and 3 inches from the pole top.

FINISHING

Carbon steel poles may be specified as hot-dip galvanized per ASTM A123 and/or finish painted with our standard Millerbond Wet Coat Finish.

HARDWARE

All hardware and fasteners are supplied with each pole assembly. All structural fasteners are galvanized high-strength carbon steel.

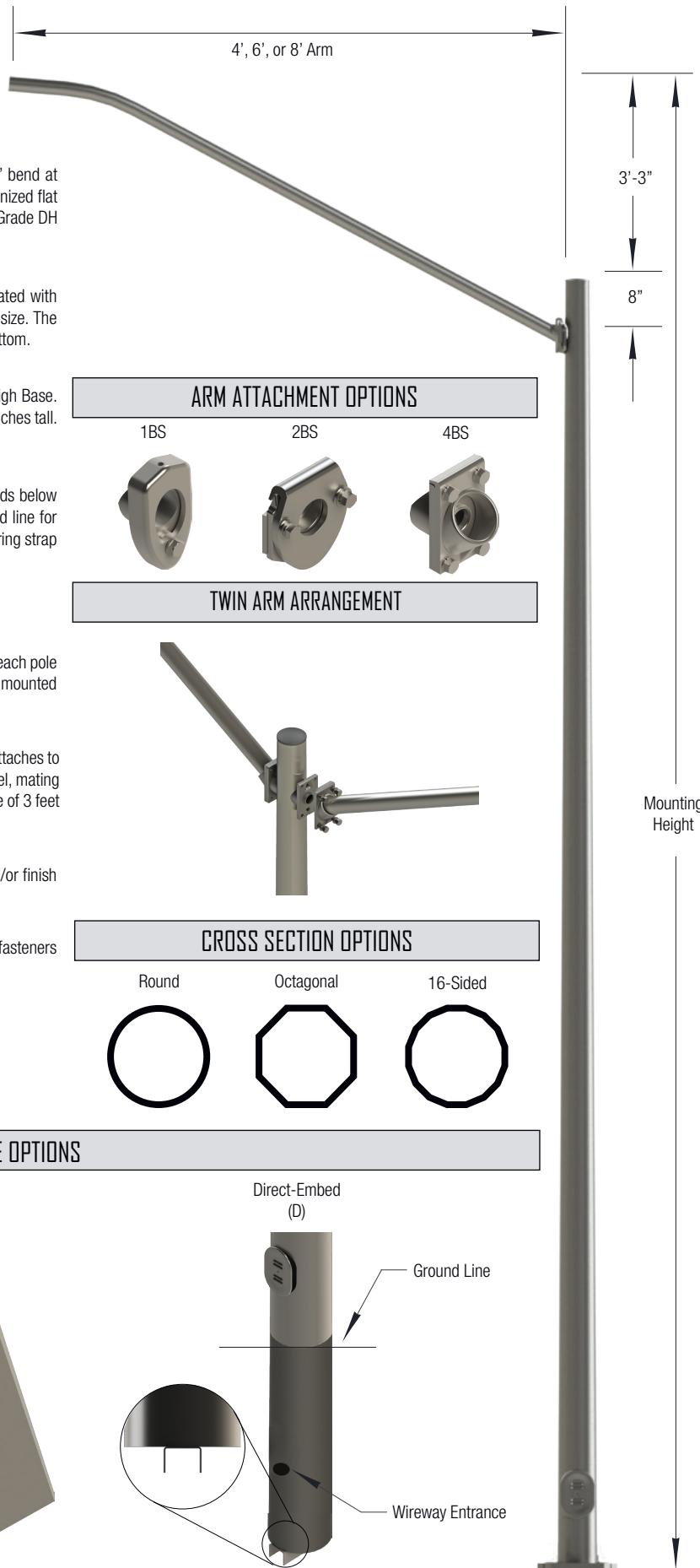

ARM ATTACHMENT OPTIONS

1BS

2BS

4BS

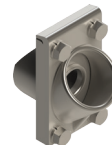
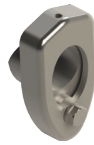

TWIN ARM ARRANGEMENT



CROSS SECTION OPTIONS

Round

Octagonal

16-Sided

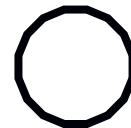
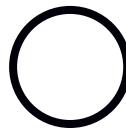

BASE OPTIONS

Anchor Base
(A)

High-Base
(H)

Direct-Embed
(D)

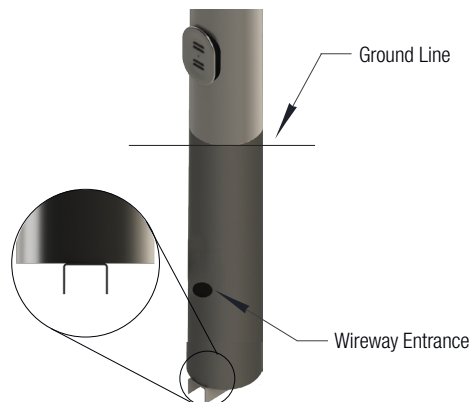
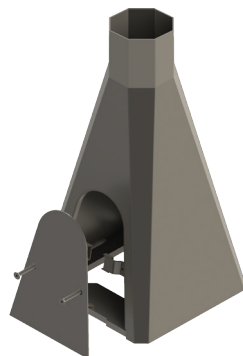
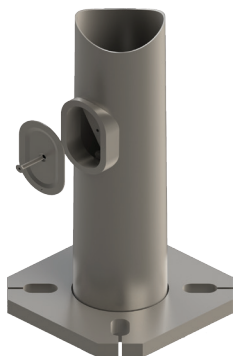



ANCHOR BASE

PART#	MOUNTING HEIGHT (FT)	MAX ARM LENGTH (FT)	WEIGHT (LBS.)	BASE O.D. (IN)	TOP O.D. (IN)	BOLT CIRCLE +/- 0.5 (IN)	BASE SQUARE (IN)	MAX EPA 90 MPH	MAX EPA 100 MPH	MAX EPA 110 MPH	MAX EPA 120 MPH	MAX EPA 130 MPH	MAX EPA 140 MPH	MAX EPA 150 MPH
SP1-081-A-060-A-200	20	8	157	6	3.62	9	9	5.85	5.2	4.58	3.96	3.41	2.94	2.52
SP1-081-A-070-A-250	25	8	205	7	3.92	10	10	5.71	5.04	4.4	3.8	3.26	2.79	2.39
SP1-081-A-080-A-300	30	8	264	8	4.22	11	11	5.6	4.92	4.26	3.67	3.14	2.69	2.28
SP1-081-A-080-A-350	35	8	294	8	3.52	11	11	4.96	4.81	4.15	3.56	3.04	2.58	2.19
SP1-081-A-085-A-350	35	8	320	8.5	4.02	11.5	11.5	5.49	4.81	4.15	3.56	3.04	2.58	2.19
SP1-081-A-090-A-400	40	8	374	9	3.82	12.5	12.5	5.41	4.71	4.06	3.45	2.94	2.5	2.11
SP1-081-A-100-A-500	50	8	480	10	3.45	13.5	13.5	4.17	4.17	3.89	3.31	2.74	1.81	1.03

DIRECT-EMBEDDED BASE

PART#	MOUNTING HEIGHT (FT)	MAX ARM LENGTH (FT)	WEIGHT (LBS.)	BASE O.D. (IN)	TOP O.D. (IN)	BURIAL DEPTH (FT)	MAX EPA 90 MPH	MAX EPA 100 MPH	MAX EPA 110 MPH	MAX EPA 120 MPH	MAX EPA 130 MPH	MAX EPA 140 MPH	MAX EPA 150 MPH
SP1-081-D-060-A-200	20	8	124	6	3.62	5	5.85	5.2	4.58	3.96	3.41	2.94	2.52
SP1-081-D-070-A-250	25	8	172	7	3.92	5	5.71	5.04	4.4	3.8	3.26	2.79	2.39
SP1-081-D-080-A-300	30	8	229	8	4.22	6	5.6	4.92	4.26	3.67	3.14	2.69	2.28
SP1-081-D-080-A-350	35	8	253	8	3.52	6	4.96	4.81	4.15	3.56	3.04	2.58	2.19
SP1-081-D-085-A-350	35	8	273	8.5	4.02	6	5.49	4.81	4.15	3.56	3.04	2.58	2.19
SP1-081-D-090-A-400	40	8	320	9	3.82	7	5.41	4.71	4.06	3.46	2.94	2.5	2.11
SP1-081-D-100-A-500	50	8	432	10	3.45	8	4.17	4.17	3.89	3.31	2.74	1.81	1.03

HIGH-BASE

PART#	MOUNTING HEIGHT (FT)	MAX ARM LENGTH (FT)	WEIGHT (LBS.)	BASE O.D. (IN)	TOP O.D. (IN)	BOLT CIRCLE (IN)	BASE SQUARE (IN)	MAX EPA 90 MPH	MAX EPA 100 MPH	MAX EPA 110 MPH	MAX EPA 120 MPH	MAX EPA 130 MPH	MAX EPA 140 MPH	MAX EPA 150 MPH
SP1-081-H-070-A-200	20	8	177	7	4	15	15	5.85	5.2	5.46	3.96	3.42	2.94	2.52
SP1-081-H-070-A-250	25	8	203	7	4	15	15	5.71	5.04	4.4	3.8	3.26	2.79	2.39
SP1-081-H-086-A-300	30	8	281	8.6	4	15	15	5.6	4.92	4.26	3.67	3.14	2.68	2.28
SP1-081-H-086-A-350	35	8	308	9.6	4	15	15	5.5	4.81	4.15	3.56	3.04	2.58	2.19
SP1-081-H-096-A-400	40	8	380	9.6	4	15	15	5.41	4.71	4.06	3.47	2.95	1.93	0.61
SP1-081-H-106-A-500	50	8	482	10.6	4	15	15	5.26	4.55	3.81	1.5			

- Variations from above sizes are available. Consult factory for allowable weight and EPA ratings for custom sizes.
- Charts are for single arm configurations only. Consult factory for allowable weight and EPA ratings on twin arm arrangements.
- Charted weights include the base, pole shaft, and luminaire mounting arm.
- Unless specified otherwise, luminaire mounting arms attach to the pole shaft with a 4-bolt simplex bracket. To specify a different bracket, insert the bracket part number under options.
- The "Base O.D." measurement for direct-embedded structures is taken at the ground line.

Design	Arm Span	Base Style	Base Diameter	Wall Thickness	Mounting Height	Cross-Section	Finish	Options
SP1 -	041 = 4' 061 = 6' 081 = 8'	A = Anchor H = High D = Direct Embed	Base diameter is identified with one decimal place to identify diameter in inches. (e.g. 094 = 9.4")	A = 11 GA B = 7 GA C = 3/16" D = 1/4 "	Mounting height is identified with one decimal place to identify height in feet. (e.g. 255=25.5')	R = Round H = 8-Sided W = 16-Sided	GV = Hot Dip-Galvanize FP = Finish Paint GP = Paint Over Galvanize	Insert Part Number for options, seperated by "-"